

Product advantages

Mobile crane LTM 1080/1

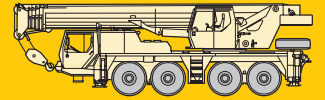

Max. lifting capacity: 80 t at 2.5 m radius
Max. height under hook: 67 m with biparted swing-away jib
Max. radius: 56 m with biparted swing-away jib



Performance profile of the LTM 1080/1 at a glance.

- Outstanding range of lifting capacities, counterweight variants 6.6 t, 8.5 t and 16 t
- Liebherr turbo-charged Diesel engine type D 9406 TI-E of 320 kW/435 h.p., exhaust gas emission acc. to EURO II, fully electronic engine management, hydraulic pump activatable for crane drive
- Compact and manoeuvrable due to all-wheel steering, smallest turning radius over carrier 8.6 m
- Data bus technique with CAN bus and Liebherr System Bus (LSB 1, 2, 3) for carrier, crane superstructure and telescopic boom
- Travel control and outrigger actuation from crane cab (standard feature)
- Comfortable electric/electronic crane control with integrated LICCON system
- Compact, 6-section telescopic boom, 10.8 m - 48 m long, with oviform boom profile of high lateral rigidity
- Rapid-cycle telescoping system „Telematik“ with patented internal interlocking system, optional fully automatic or manually controlled telescoping procedure
- 10.5 m - 19 m long biparted swing-away jib, mountable at 0°, 20° or 40°, hydraulic erection aid
- LICCON, the most modern crane computer system world-wide, with informative, monitoring and control functions
- Diesel engine, slewing rim, slewing gear, winches and hydraulic pump are self-manufactured and quality-checked components
- The LTM 1080/1 is manufactured by Liebherr within the scope of a quality assurance system according to ISO 9001

LIEBHERR

The better crane.

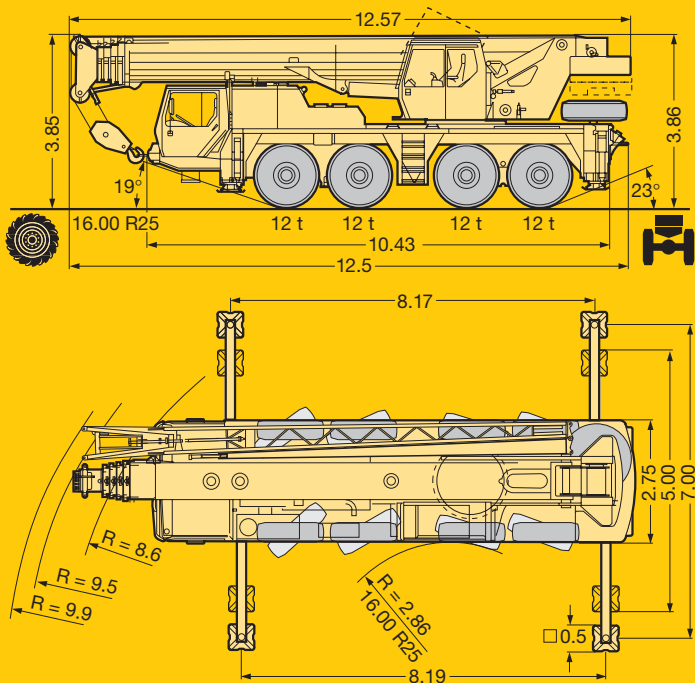

Compact, manoeuvrable and weight-optimized.

- Overall length just 12.57 m, length of carrier 10.76 m only
- Large overhang angles of up to 23°
- Smallest turning radius of 8.6 m with all-wheel steering
- 48 t total weight, incl. 8.5 t counterweight, drive 8 x 8, 16.00 tyre size, spare wheel, 32 t hook block (axle load 4 x 12 t)
- 2 optional tyre sizes
 - 14.00 R 25 - vehicle width 2.75 m
 - 16.00 R 25 - vehicle width 2.75 m

Variable drive and steering concept.

- Drive 8 x 6, axles 1, 3 and 4 are driven, for road travel only 3rd and 4th axle are driven, 1st axle activatable for off-road travel
- Drive 8 x 8 (optional), all axles are driven, for road travel only 3rd and 4th axle are driven, axles 1 and 2 activatable for off-road travel
- All-wheel steering, 3th and 4th axle also steerable independent of axles 1 and 2 (crab steering), the additional hydraulic steering is mechanically locked during road travel; all steering versions can equally be performed from the crane cab

Setting crane on outriggers - quick, convenient and safe.

- Variable supporting basis
 - Outriggers retracted
 - Supporting basis 5 x 8.18 m
 - Supporting basis 7 m x 8.18 m
- Fixed-mounted supporting pads, protected by splash guards
- Supporting ram travel up to 700 mm
- 2 x 8° lateral inclination of carrier and crane superstructure
- The operator's panels with membrane keyboard and reflecting level as well as with keyboard for ENGINE/START/STOP and speed control are illuminated and lockable
- Operation of the outrigger system in accordance with the rules for the prevention of accidents

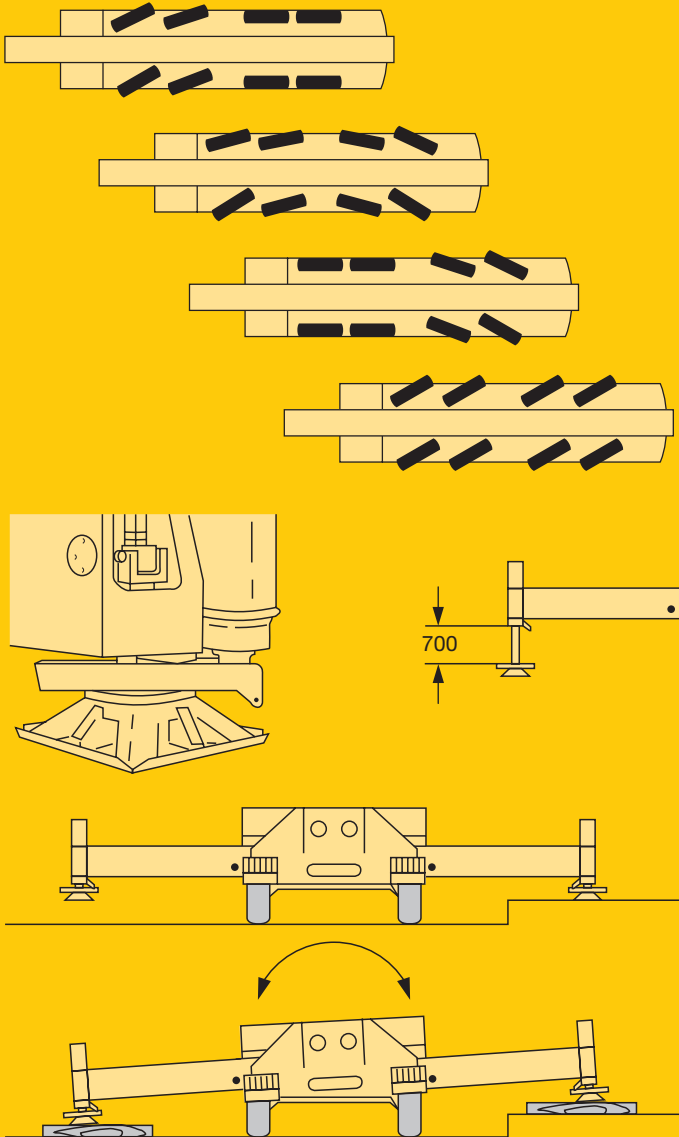

The LTM 1080/1 - more benefit through advanced technology.

Torsional rigid telescopic boom.

- Ovoid boom profile of particular inherent stability
- Telescopes mounted on maintenance-free polyamide slide pads
- First-rate lifting capacities, e.g.
 - 21.6 t at 10 m radius
 - 7.1 t at 20 m radius
 - 4.1 t at 30 m radius
 - 2.0 t at 40 m radius
 - 0.6 t at 56 m radius
- Telescoping by rapid cycle approx. 280 s for boom length 10.8 m - 48 m

Modern and powerful carrier and crane drive.

- Economical single-engine concept
- 6-cylinder Liebherr turbo-charged Diesel engine of 320 kW/435 h.p. (EURO II), robust and reliable, with electronic engine management
- Entire exhaust gas system of stainless steel
- ZF power shift gear type 6 WG 260 with torque converter and lock-up clutch, electronic gear management, 6 forward, 1 reverse speed, integrated rough-terrain ratio
- Max. driving speed 80 km/h, max. gradability 60 %
- Liebherr double axial piston variable displacement pump driven by the Diesel engine, activatable for crane operation

Spacious crane cab with comfortable, armrest-integrated control elements.

- Steel-fabricated, corrosion resistant crane cab, powder-coated, with internal sound and heat insulating panelling, tinted panes all-round, front knockout window with parallel windscreen wiper, skylight of bullet-proof glass with parallel windscreen wiper, roller blinds on front window and skylight, space saving sliding door
- Crane cab tiltable backwards by 20°
- Operator's seat with pneumatic lumbar support
- Modern instrument support with integrated LICCON monitor
- Operator-friendly, armrest-integrated controls, vertically and horizontally adjustable as well as inclinable master switch consoles and armrests, ergonomically inclined operator's consoles

Liebherr components - reliable and easy to service.

- Diesel engine, slewing rim, slewing gear, the winches and the double axial piston variable displacement pump are self-manufactured Liebherr components specially matched for the application on mobile cranes
- The centralized lubricating system for slewing rim, boom bearing application, luffing ram and winch bearings is a standard feature

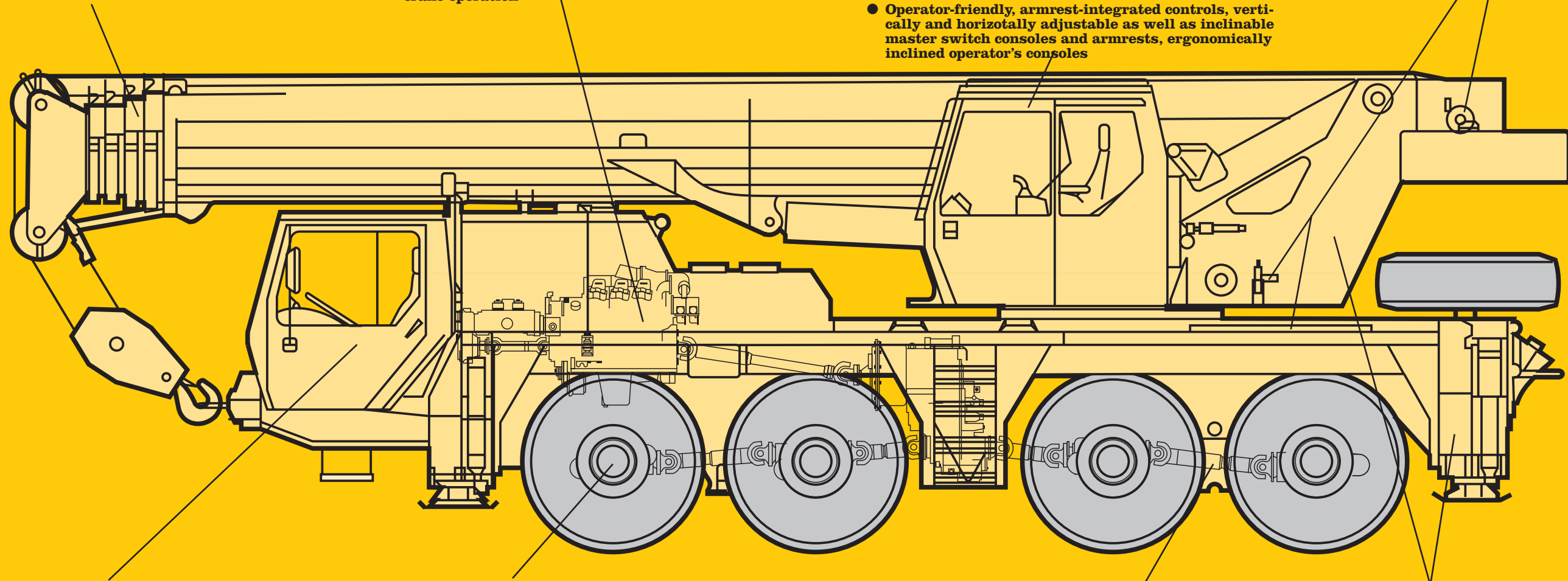

Wide and comfortable driving cab.

- Wide, steel-made, corrosion resistant driving cab, cataphoretic dip-primed and entirely powder coated, front section mounted on rubber shock absorbers, rear section on hydraulic dampers, modern interior design of outstanding functionality
- Safety glass all round
- Air-cushioned driver's seat with pneumatic lumbar support, air-cushioned co-driver's seat
- Standardized digital operating and control elements arranged in an operator-friendly half-round shape
- Steering wheel adjustable in height and inclination, heatable and electrically adjustable exterior mirrors, electric window lifters

Outstanding carrier technology for road and off-road application.

- Weight-optimized axles, almost maintenance-free, made of high-tensile steel, perfect track keeping and lateral stability due to special control linkage arrangement
- The maintenance-free steering knuckles are steel and rubber mounted
- The perfected and robust axles are manufactured in large series and are troublefree components
- The cardan shafts are maintenance-free; easy and quick fitting of the cardan shafts due to 70° diagonal toothing and 4 fixing screws

Niveaumatik suspension - preserving crane and roads.

- Maintenance-free suspension rams, free of lateral forces, protected against damage by synthetic tubes
- Level position (suspension on „travelling mode“) can be adjusted automatically by push-button control from the driving cab at any position
- Stable cornering ability due to cross mounting of the hydropneumatic suspension
- Axle locking system (locking of the suspension for displacement with loads) controlled from the driving cab
- Suspension travel +/- 100 mm

Weight-optimized steel structure.

- Steel structure of the carrier, superstructure and telescopic boom in light-gauge design, calculated by the F.E.M. method, weight-optimized and of outstanding torsional rigidity
- Tensile property of the material with high safety factors through the application of STE 960 (960 N/mm²) for all supporting members
- Welds of the highest quality are guaranteed by the application of computer-aided welding machines
- The quality of welds is documented by ultrasonic test

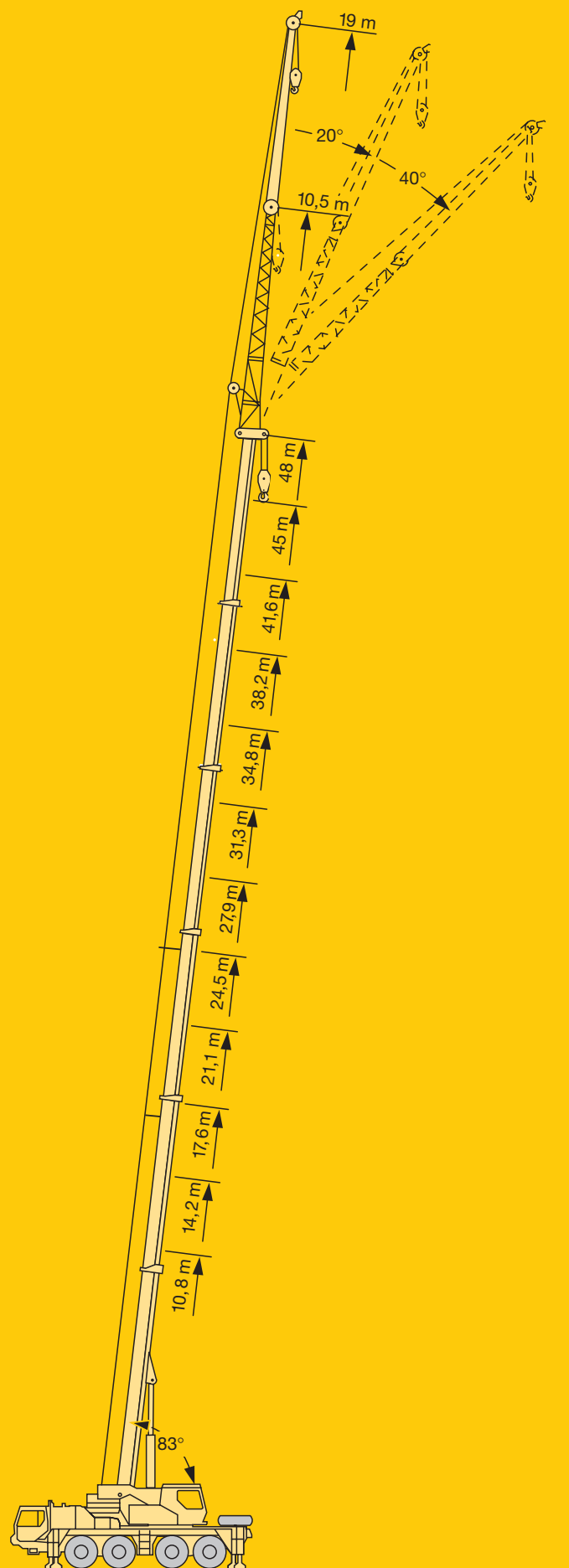

Lifting loads - precise and safe.

- 6-section, 48 m long telescopic boom and biparted 19 m long swing-away jib for 67 m height under hook and 54 m radius
- Telescopic boom with rounded, oviform bottom shell, thus maximum lateral rigidity
- Optimal utilization of the telescopic boom through a multitude of telescoping options
- Swing-away jib mountable at 0°, 20° or 40°, hydraulic fitting aid
- Easy and quick re-reeving of the hoist rope through a modern self-locking rope dead end connection; cylindrically shaped load hook may easily be displaced as it can be rolled on hard surface

oval cross-section

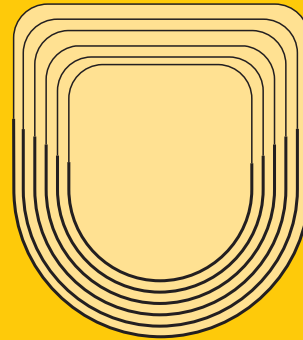

LICCON-aided telescoping system.

- Telescoping by means of a single-action hydraulic ram with hydraulically actuated driving pins (patented internal interlocking device)
- Telescoping procedure controllable by convenient operator's guide on the monitor; precise approach of interlocking positions
- Telescopic loads are displayed on the LICCON operating image
- Rapid-cycle telescoping system with „automatic operation“, i.e. fully automatic telescoping to the desired boom length
- Particularly compact and light-weight telescoping system, thus increase of lifting capacities, especially with long booms and at large radii
- Automatic cushioning in end positions during telescoping and retracting for preserving the structural members

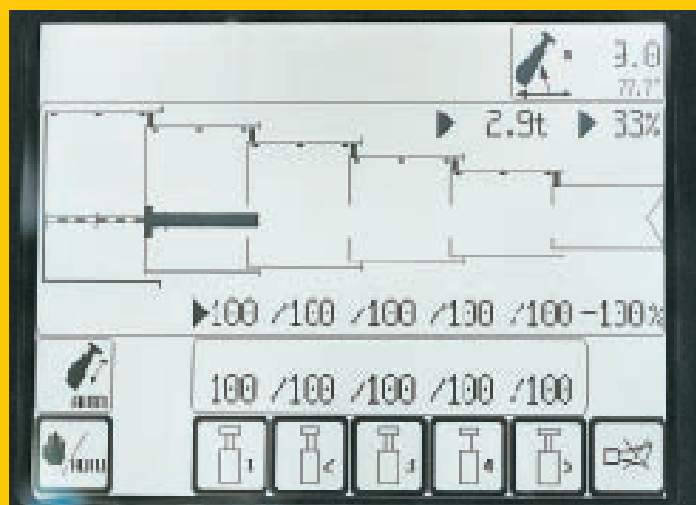

- The electric and electronic components are interlinked by the most modern data bus transmission technique
- The Diesel engine and power shift gear are controlled by means of a CAN data bus. The fully electronic drive management reduces fuel consumption and improves the exhaust gas emission.
- The carrier and crane electric systems, including all cockpit functions, the outrigger system and the boom sensor system, are interlinked by three Liebherr System Busses (LSB 1, 2, 3)
- Instead of the traditional electric wiring system, the data transmission to the individual functional units is performed digitally via a few data cables
- The activation of the function blocks is realized by I/A modules the programming of which is performed via the Liebherr system busses. The control intelligence is integrated into the LICCON central unit.
- The new data bus technique clearly contributes to an increase in functionality and efficiency as well as to the ease of servicing and diagnostic.

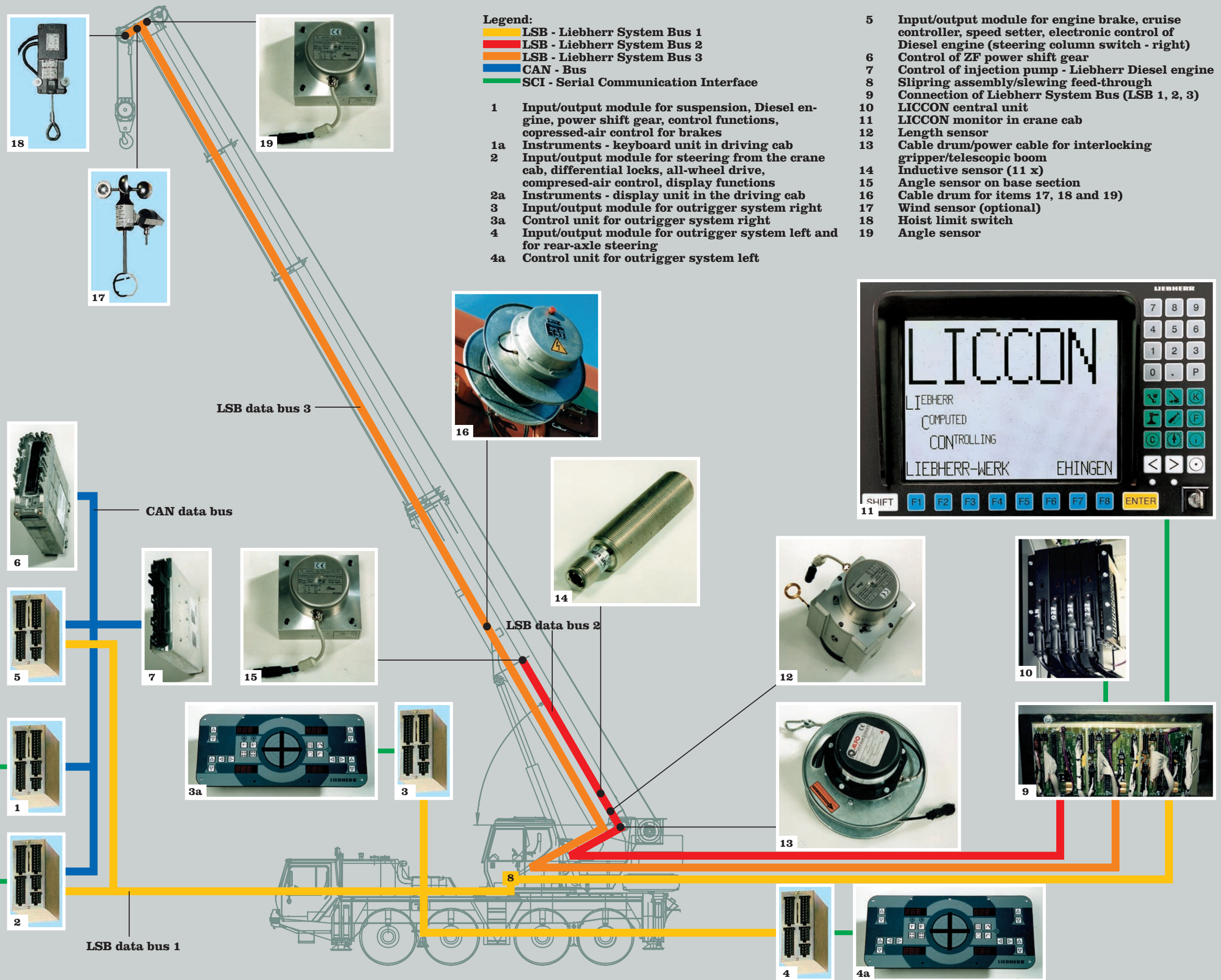

Data bus technique revolutionizes crane electric system.

LICCON computer system with safe load indicator and test system.

- Setting of crane configuration by convenient conversational functions
- Reliable acknowledgement of the crane configuration set
- Representation of all essential data by graphic symbols on the operating image
- With integrated wind speed control (optional)
- Reliable cut-off device in the event of exceeding the permissible load moments
- Indication of lifting capacities for any boom intermediate length
- Winch indications for ultra-precise lifting/lowering of the load
- Test system for servicing, providing the facility to check all sensors connected to the system on the monitor

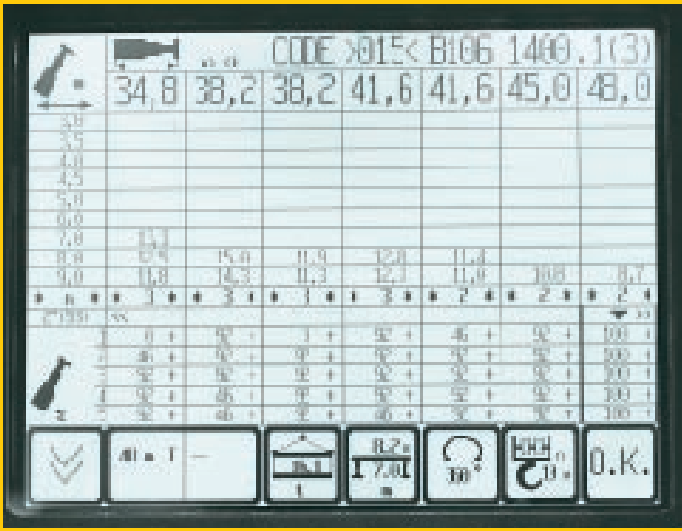

Mounting of counterweight - just a matter of minutes.

- Counterweight variants 6.6 t, 8.5 t and 16 t
- Ballasting controlled from crane cab, without auxiliary crane
- Quick ballasting due to "keyhole" system
- Compact counterweight dimensions, e.g. 16 t counterweight of 2.73 m width only

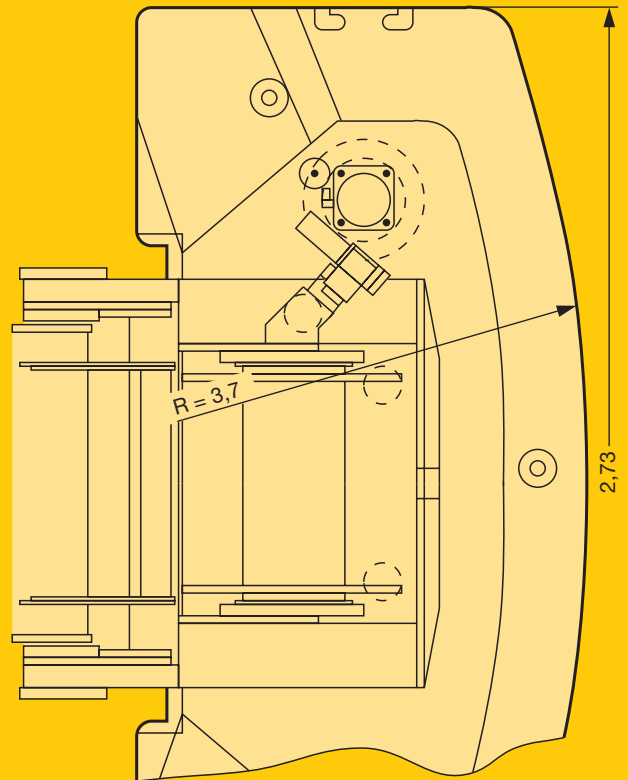
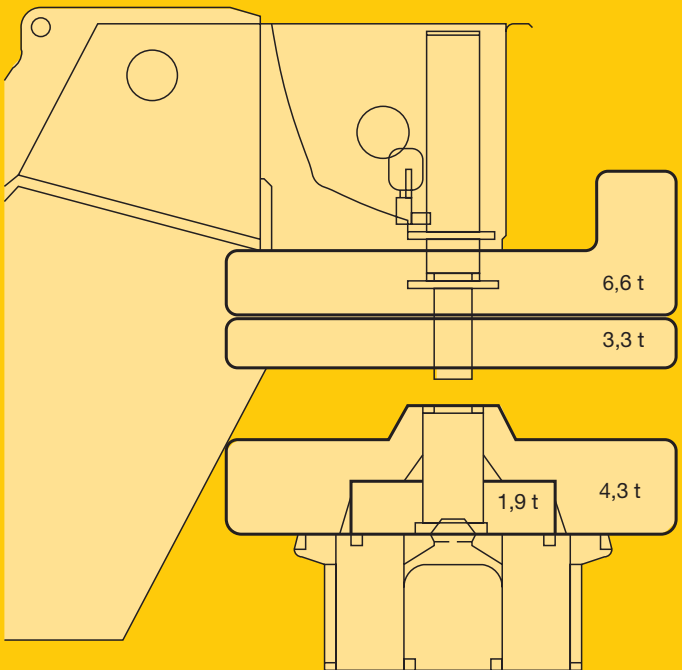
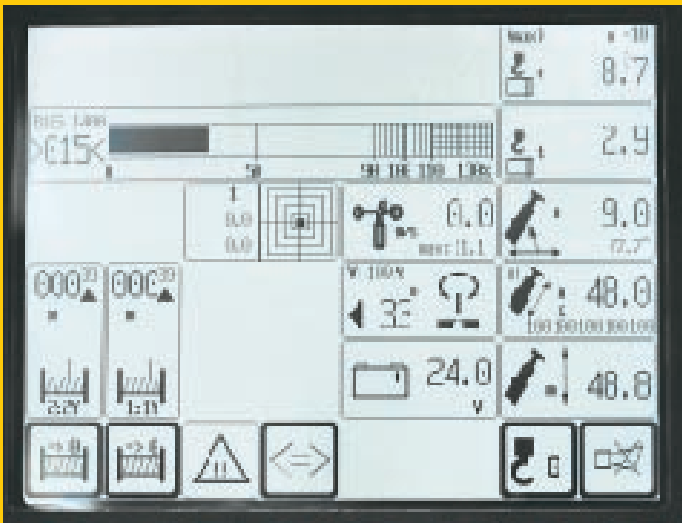

Electric/electronic PLC crane control with test system.

- Control of the winches, slewing gear as well as of the luffing and telescoping motions by means of the LICCON computer system (PLC control)
- Electric load sensing, summation regulated open oil circuits, i.e. both pumps can be switched to one consumer
- Four working motions can be performed independent of one another
- High-speed activation, even during a working motion
- Luffing and slewing speeds preselectable in 5 steps
- Extremely short reaction times at the selection of crane motions
- Functional test of all essential components by means of the LICCON test system

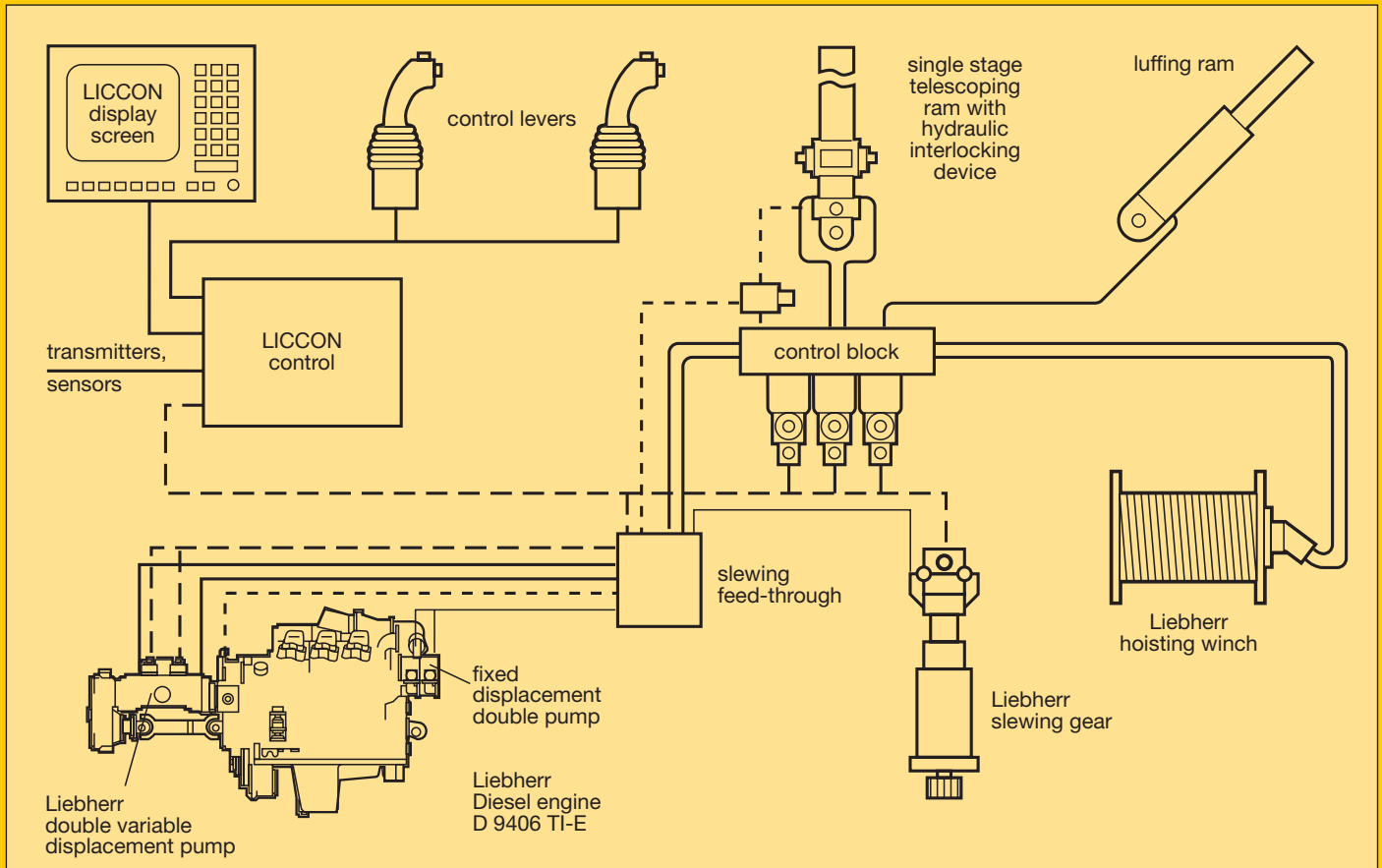

Optional features extend the application spectrum and increase comfort and safety.

On the carrier

- Auxiliary heating with engine pre-heating
- Eddy current brake
- Outrigger control
- Supporting pressure indication on the carrier and in crane operator's cab
- Electric fuelling pump
- Rope box/tool box
- Air conditioning equipment
- Trailer coupling D 12/D19
- Radio preparation
- Headlight washing device
- Antiskid system in conjunction with automatic track control
- Tyre size 20.5 R 25

On crane superstructure/telescopic boom

- Air conditioning equipment
- Seat heating
- Mirror mounting on superstructure
- Working area limitation
- Mast nose on telescopic boom
- Short special auxiliary boom
- Wind warning telescopic boom/swing-away jib
- Aircraft warning beacon
- Preparation for high voltage warning on telescopic boom/swing-away jib
- Working projector 2 x 70 W on telescopic boom base section
- Working projector 2 x 70 W on telescopic boom head section
- Twist absorber

Further optional features by request.

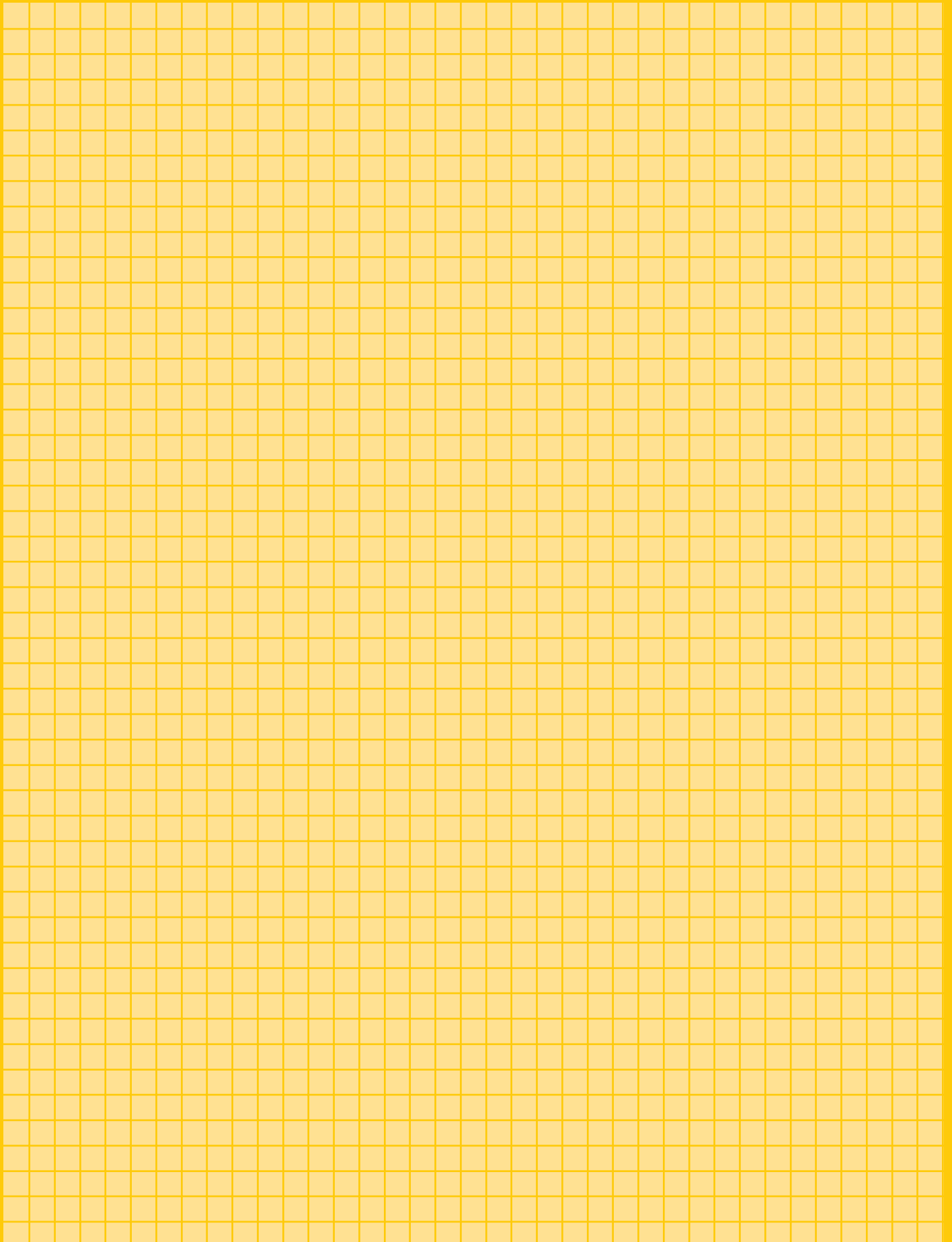

Subject to modification.

TP 275a.7.98

Please contact
LIEBHERR-WERK EHINGEN GMBH, Postfach 1361, D-89582 Ehingen
☎ (073 91) 5 02-0, Fax (073 91) 5 02-399

CD-